



Features

- Broad band UVA-UVB-UVC photodiode in TO18 metal package
- Silicon Carbide based chip for extreme radiation hardness
- Chip dimensions of $1 \times 1 \text{ mm}^2$ with 0.96 mm^2 active area
- Intrinsic visible blindness due to wide-bandgap semiconductor material
- Completely insensitive to the visible ($S_{280\text{nm}} / S_{400\text{nm}} > 10^4$) without filters
- The chip is manufactured by Cree Research Inc., U.S.A.

Eigenschaften

- Breitband UVA-UVB-UVC Photodiode im TO18 Metallgehäuse
- Siliziumkarbidchip garantiert extreme Strahlungsfestigkeit
- Chipabmessungen von $0.5 \times 0.5 \text{ mm}^2$ mit 0.22 mm^2 aktiver Fläche
- hohe intrinsische Unempfindlichkeit gegenüber dem sichtbaren Licht durch Halbleitermaterial mit hoher Bandlücke
- Vollständig unempfindlich für sichtbares Licht ($S_{280\text{nm}} / S_{400\text{nm}} > 10^4$) ohne Filtereinsatz
- Chiphersteller: Cree Research Inc., U.S.A.

SG01L-18

Maximum Ratings

Parameter	Symbol	Value	Unit
Operating temperature range	T_{opt}	-25 ... +70	°C
Reverse voltage	V_{Rmax}	20	V

General Characteristics

($T_a = 25\text{ °C}$)

Parameter	Symbol	Value	Unit
Active area	A	0.96	mm ²
Dark current at 1 V reverse bias	I_d	5	fA
Capacitance	C	200	pF
Short circuit current at bright sun	I_0	ca. 800	nA

Spectral Characteristics

($T_a = 25\text{ °C}$)

Parameter	Symbol	Value	Unit
Max. spectral sensitivity	S_{max}	0.13	A W ⁻¹
Wavelength of max. spectral sensitivity	λ_{Smax}	280	nm
Range of spectral sensitivity ($S=0.1*S_{max}$)	-	220 - 360	nm

SG01L-18

Linear Spectral Response

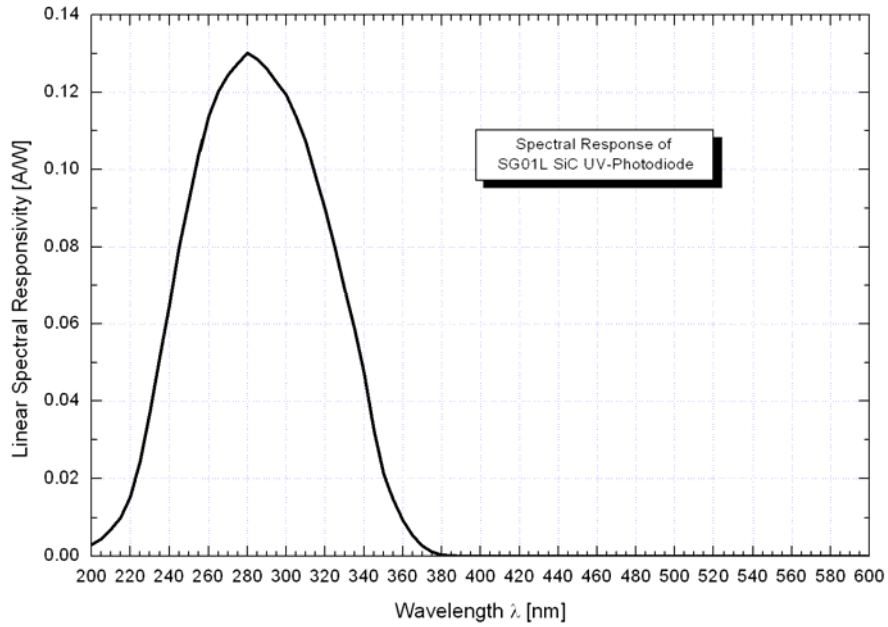

SG01L-18

Logarithmic Spectral Response

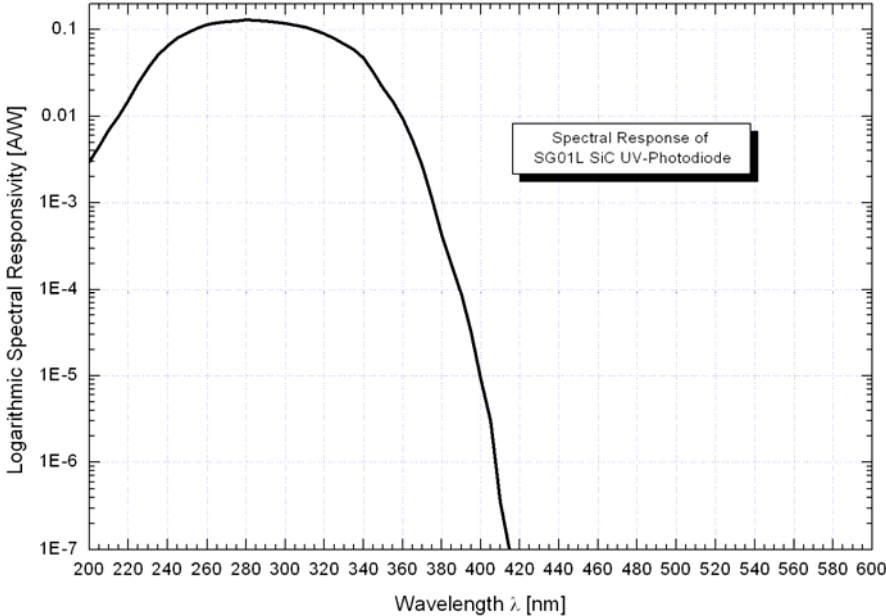

Ultraviolet selective SiC based UV sensor



SG01L-18

Application Example

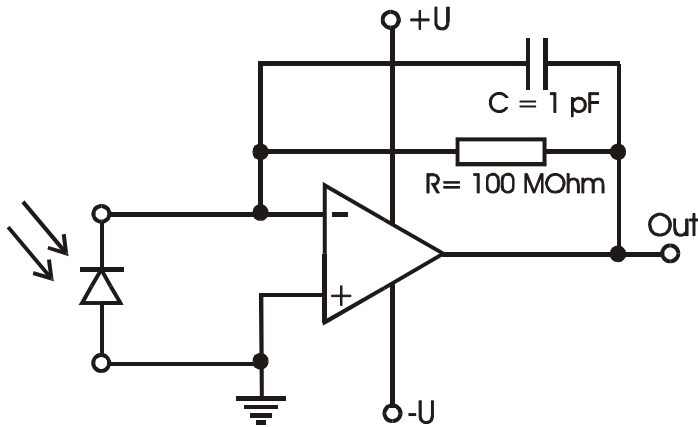

Pin Layout

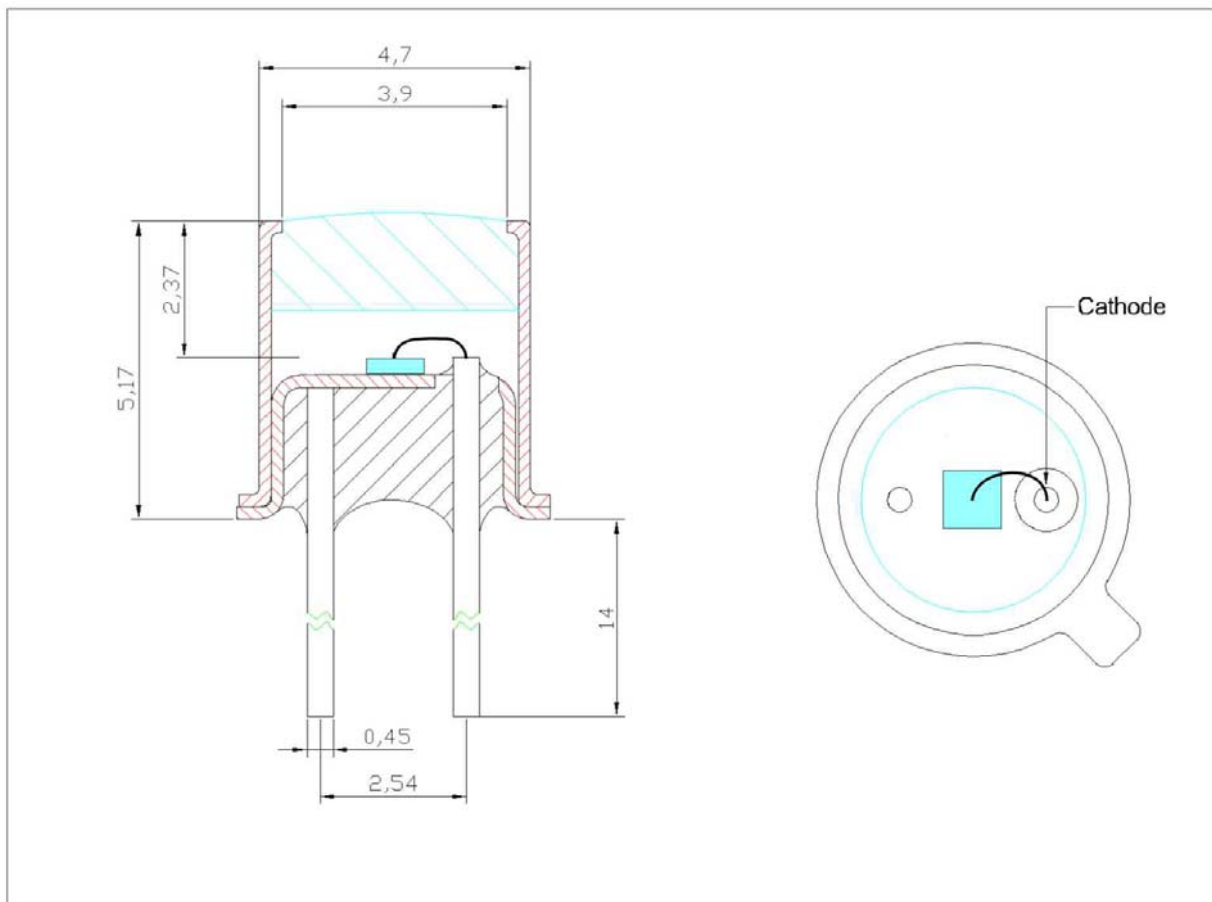

Rev. 1.4

Page 5 [5]

PRC Technologies Corporation Ltd.

328/65 Ladprao 87 Rd, Wangthonglang, Bangkok 10310
T: 02 530-1714, 530-1619, 530-1621; F: +662 530-1731

www.prctechnologies.co.th