



### **Features**

- Two insulated pins
- Broad Band UVA-UVB-UVC Photodiode
- Optimally suited for UVC high radiation control
- Silicon Carbide based chip for extreme irradiation hardness
- Intrinsic visible blindness due to wide-bandgap semiconductor material
- TO-18 metal package with 0,054 mm<sup>2</sup> active chip area
- The chip is manufactured by Cree Research Inc., U.S.A.

### **Eigenschaften**

- Beide Anschlüsse zur Gehäusemasse isoliert
- Breitband UVA-UVB-UVC Photodiode
- Optimale Eignung für Messung starker UVC-Strahlung
- Siliziumcarbid-Chip garantiert extreme Strahlungsfestigkeit
- hohe intrinsische Unempfindlichkeit gegenüber dem sichtbaren Licht durch Halbleitermaterial mit hoher Bandlücke
- TO-18 Metallgehäuse mit 0,054 mm<sup>2</sup> aktiver Chipfläche
- Chiphersteller: Cree Research Inc., U.S.A.

# Ultraviolet selective SiC based UV sensor



## SG01S-ISO

### Maximum Ratings

Parameter	Symbol	Value	Unit
Operating temperature range	$T_{opt}$	-25 ... +70	°C
Reverse voltage	$V_{Rmax}$	20	V

### General Characteristics

( $T_a = 25\text{ °C}$ )

Parameter	Symbol	Value	Unit
Active area	A	0.054	mm <sup>2</sup>
Dark current at 1 V reverse bias	$I_d$	1	fA
Capacitance	C	21	pF
Short circuit current at bright sun	$I_0$	ca. 70	nA

### Spectral Characteristics

( $T_a = 25\text{ °C}$ )

# Ultraviolet selective SiC based UV sensor



## SG01S-ISO

Parameter	Symbol	Value	Unit
Max. spectral sensitivity	$S_{\max}$	0,13	$A W^{-1}$
Wavelength of max. spectral sensitivity	$\lambda_{S_{\max}}$	285	nm
Range of spectral sensitivity ( $S=0.1*S_{\max}$ )	-	210 - 380	nm

## SG01S-ISO

### Linear Spectral Response

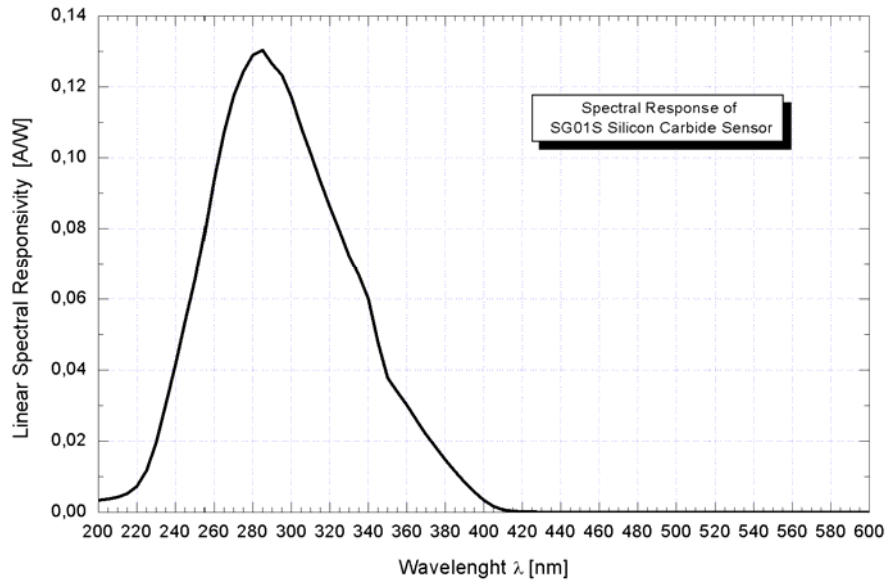

### Logarithmic Spectral Response

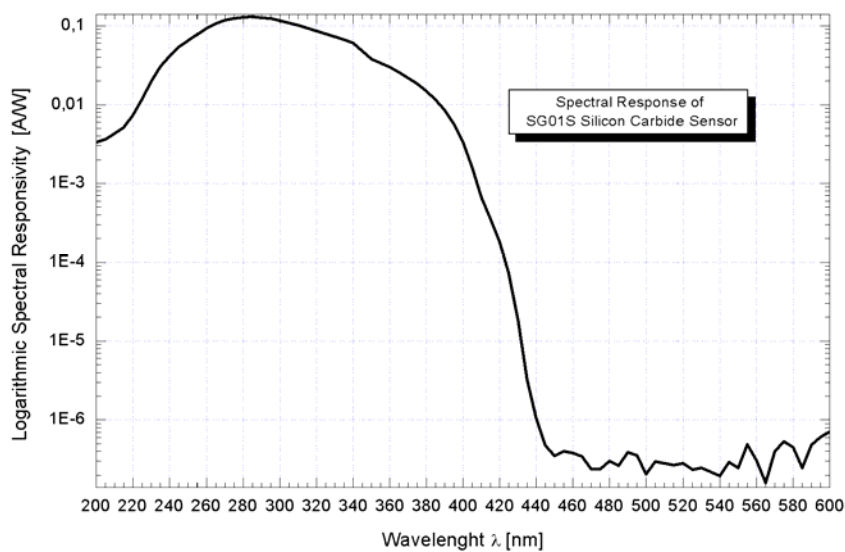

# Ultraviolet selective SiC based UV sensor



## SG01S-ISO

### Application Example

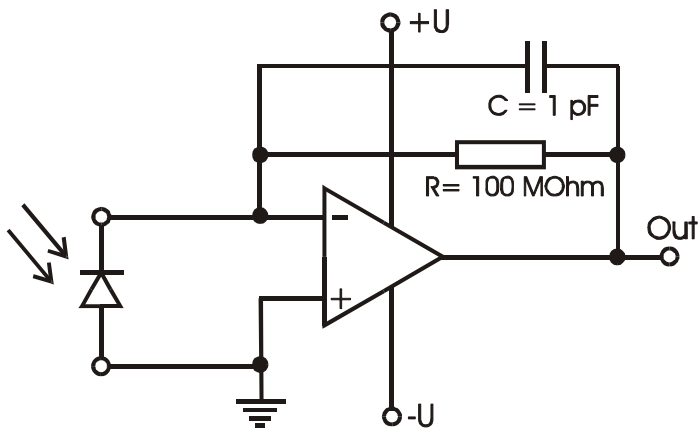

### Pin Layout