



Features

- UVC Photodiode with small photoactive area
- Optimally suited for detection and control of strong UVC radiation
- Silicon Carbide based chip for extreme irradiation hardness
- Spectral Response in accordance with DVGW W 294
- TO-18 metal package with 0.054 mm² active chip area
- The chip is made by Cree Research Inc., U.S.A.
- Radiation-hard UVC interference filter is made in Germany

Eigenschaften

- UVC Photodiode mit kleiner photoaktiver Fläche
- Optimale Eignung für Messung starker UVC-Strahlung
- Siliziumcarbidge-Chip garantiert extreme Strahlungsfestigkeit
- Spektrale Empfindlichkeit in Übereinstimmung mit DVGW W 294
- TO-18 Metallgehäuse mit 0,054 mm² aktiver Chipfläche
- Chiphersteller: Cree Research Inc., U.S.A.
- Der strahlungsharte Interferenzfilter wird in Deutschland hergestellt

SG01S-C18

Maximum Ratings

Parameter	Symbol	Value	Unit
Operating temperature range	T_{opt}	-25 ... +80	°C
Reverse voltage	V_{Rmax}	20	V

General Characteristics

($T_a = 25\text{ °C}$)

Parameter	Symbol	Value	Unit
Filter aperture	D	2,1	mm
Filter aperture area	a	3,46	mm ²
Active area	A	0,054	mm ²
Dark current at 1 V reverse bias	I_d	1	fA
Capacitance	C	21	pF
Short circuit current for 10 mW/cm ² @ 254 nm	I_0	ca. 350	nA

SG01S-C18

Spectral Characteristics

($T_a = 25\text{ }^\circ\text{C}$)

Parameter	Symbol	Value	Unit
Max. spectral sensitivity	S_{\max}	0.11	A W^{-1}
Wavelength of max. spectral sensitivity	$\lambda_{S_{\max}}$	270	nm
Range of spectral sensitivity ($S=0.1 \cdot S_{\max}$)	-	230 - 285	nm

Linear Spectral Response

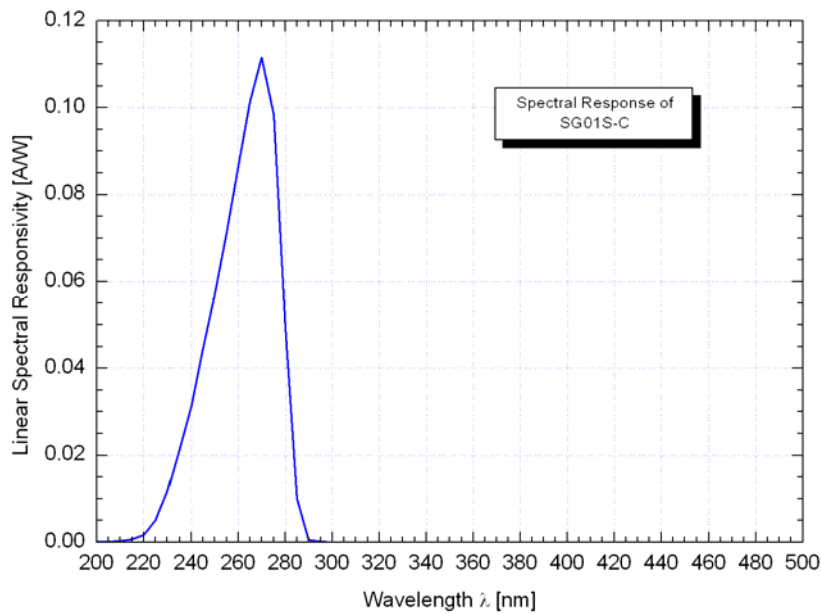

Logarithmic Spectral Response

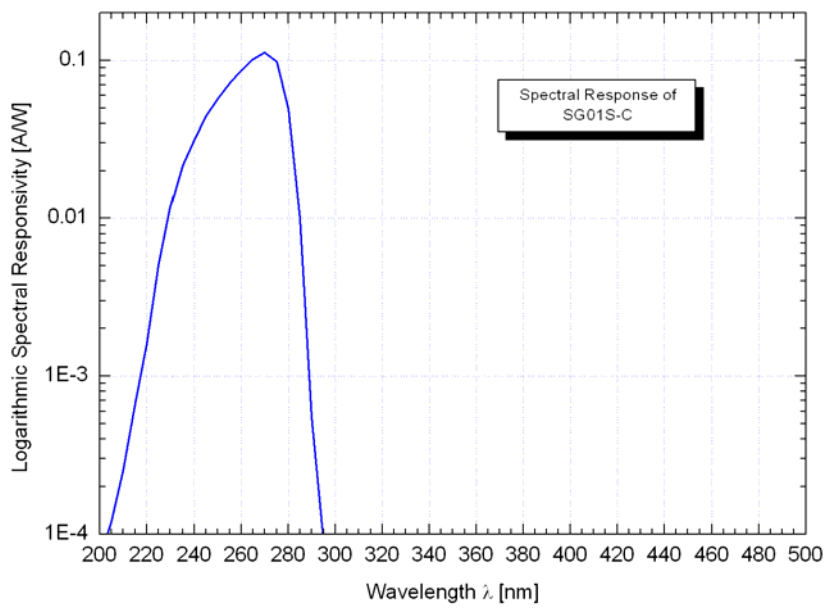

SG01S-C18

Application Example

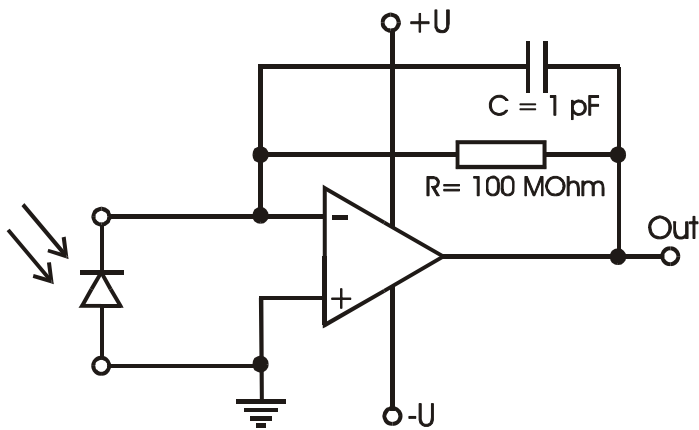

Dimensions

