

Temptool

Temptool is the Temperature Measurement Board measures temperature from -25°C up to +115 °C using Smartec's temperature sensors and sends the temperature as a standard ASCII string. The kit is based on a Microchip's PIC12C509 microcontroller and uses a RS232 interface (COMx port) to communicate with a standard personal computer. Up to 4 sensors can be connected simultaneously, the software will test all the inputs automatically on power up and after that it will process only the ones with sensors connected. The measurement will start automatically after the user plugs in the board in a serial interface connector of course after configuration of the corresponding COM port. The board can be plugged directly into the computer. Only four lines of the RS232 standard 9-pin connector are used: pin 2 (RD), pin 3 (TD), pin 5 (GND) and pin 7 (RTS). **If an extension cable is used it must have a strait connection.** A LED on the board will indicate a proper connection. The measurement results of different sensors are separated in the output string by a 'SPACE' (\$20). The consecutive measurements are separated by LF, CR (\$0D, \$0A) commands. Each measured value is send in 4 or 5 bytes. For instance 20.1 °C is send as 2 then 0 then . and 1. In case the temperature is above 100 °C an extra byte is send '1' and in case the temperature is negative a minus is send before.

One measurement and calculation takes approximately 500 ms.

If you have only one sensor connected it should be placed on position 2 of the board (connected with pin GP2 of the PIC12C509). In case the user does not want to connect a sensor on position 2 the input should be connected to Vdd directly. Starting the board with pin GP2 floating will result in unstable functioning. In case less then 4 sensors are connected the output string will be shorter.

Every program capable to receive standard ASCII strings, for example Hyper Terminal of Windows 95/98/NT, can visualize the results. If the user prefers his own program he should power the board by putting pin 7 (RTS) in logical 0 (+12V). **If the demonstration board has to be used on a computer system that uses 5V for the logical 0 on the serial interface (laptops, notebooks, etc.), it needs to be connected to an external power supply.**

The serial port communication has to be configured in the following way:

Baud Rate: 9 600 Data bits: 8 Stop bit: 1 Parity check: None
Flow control: None

The measurement will start immediately after the board is placed into the serial port and the controlling program is started. At the same time the LED on the board will light. If it does not, check the serial port connection and configuration.

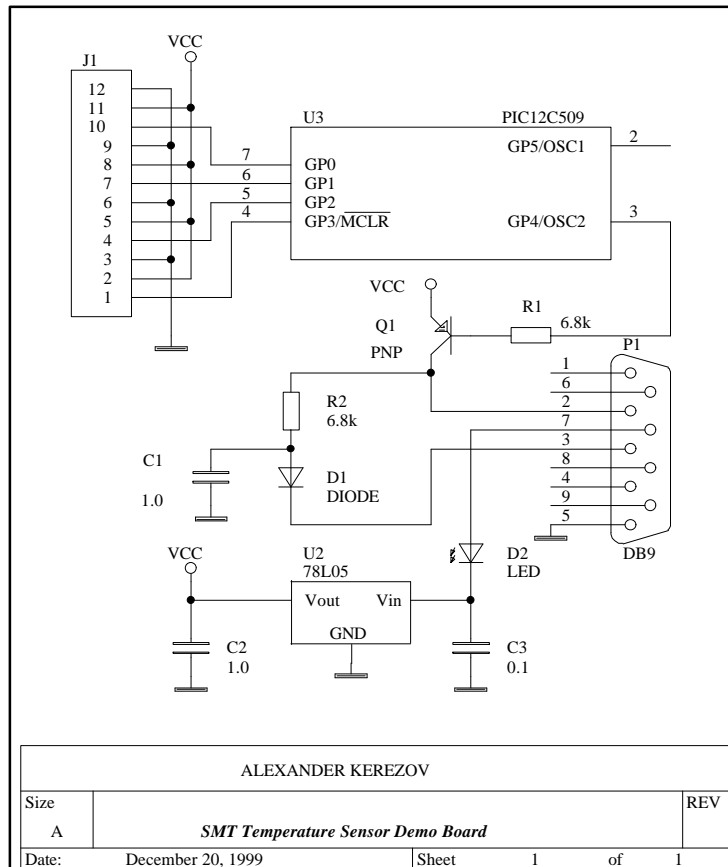

Temperature Sensor Demonstration Board Schematic

Pinout of sensor connector J1:

- 1 Output sensor 1
- 2 Vcc sensor1
- 3 Gnd sensor 1
- 4 Output sensor 2
- 5 Vcc sensor 2
- 6 Gnd sensor 2
- 7 Output sensor 3
- 8 Vcc sensor 3
- 9 Gnd sensor 3
- 10 Output sensor 4
- 11 Vcc sensor 4
- 12 Gnd sensor 4

Pinout of DB9 connector to PC:

- 2 RD
- 3 TD
- 5 GND
- 7 RTS

Program Flow chart

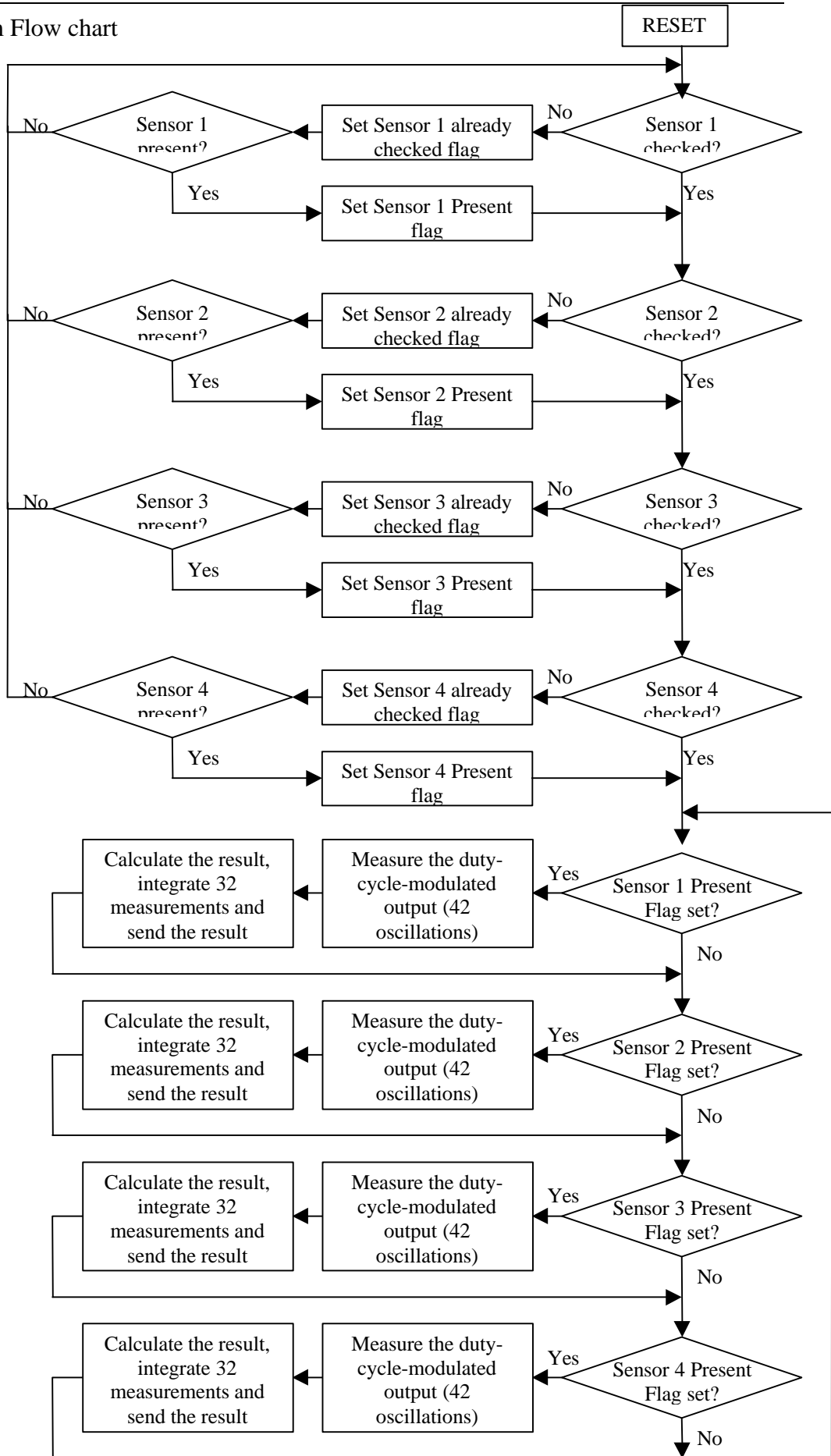

The measurement routine is based on a free running 8-bit timer TMR0. That limits the minimum and the maximum temperatures to be measured to -25°C and +115°C respectively. The flowchart of the measurement routine is shown on the figure:

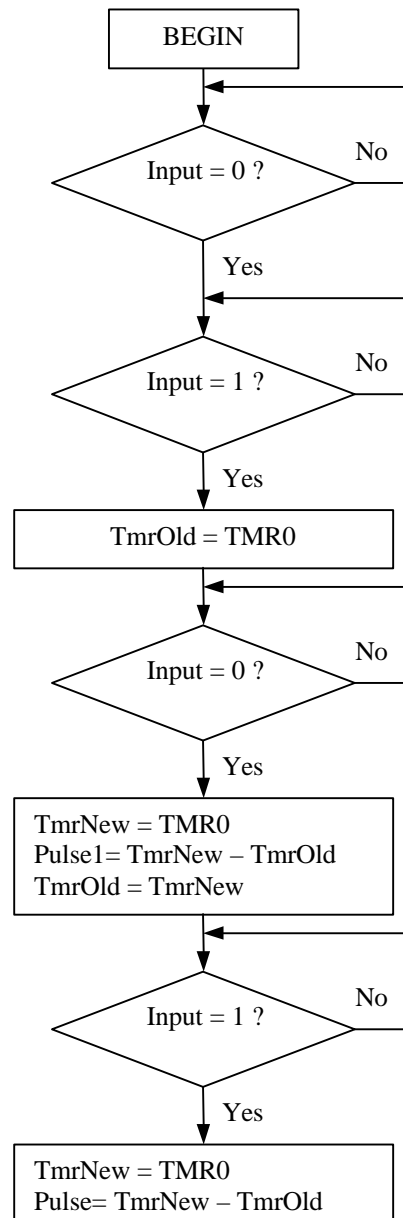

The result is calculated according to the formula:

$$\text{D.C.} = \text{Pulse1} / (\text{Pulse0} + \text{Pulse1})$$

$$\text{Temperature} = (\text{D.C.} - 0.3200) / 0.0047$$

This small PC-board is only developed as a demonstrator to show the ease of interfacing temperature sensors to micros. For the specifications of the Smartec temperature sensor please refer to the specification sheet.

TEMPTOOL



PRC Technologies Corporation Ltd.,

T: 02 9322154 , 02 932-3118

F: 02 932 3116